

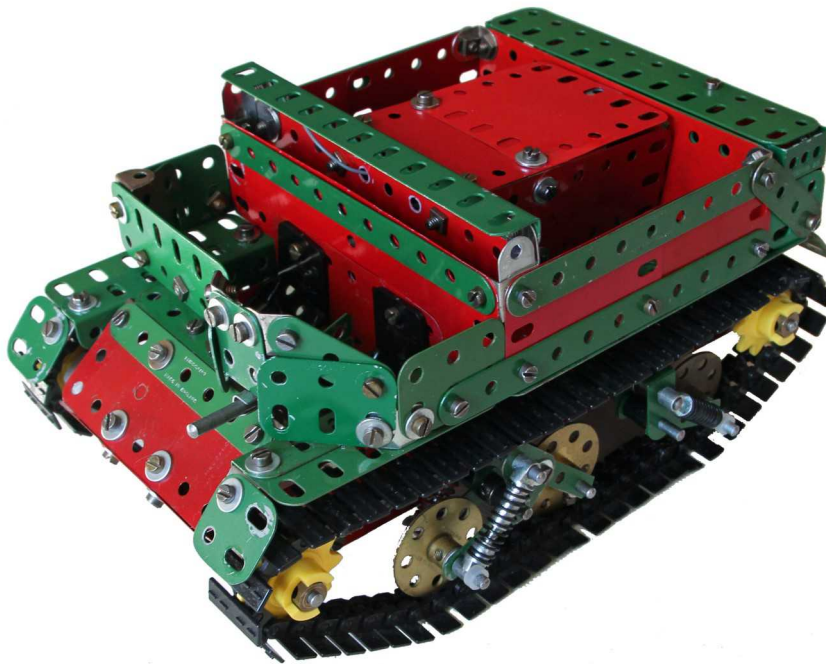

NZFMM MAGAZINE

Volume 43, No. 1

February 2019



INSIDE:

- An exquisitely detailed combine harvester to build, from Mr Tractor — aka Bruce Geange
- Make your Meccano smarter — Part 2 by Bruce Durdle
- Branch activity reports
- Auckland Marklin report
- NZFMM 2019 Easter Convention - all you need to know.

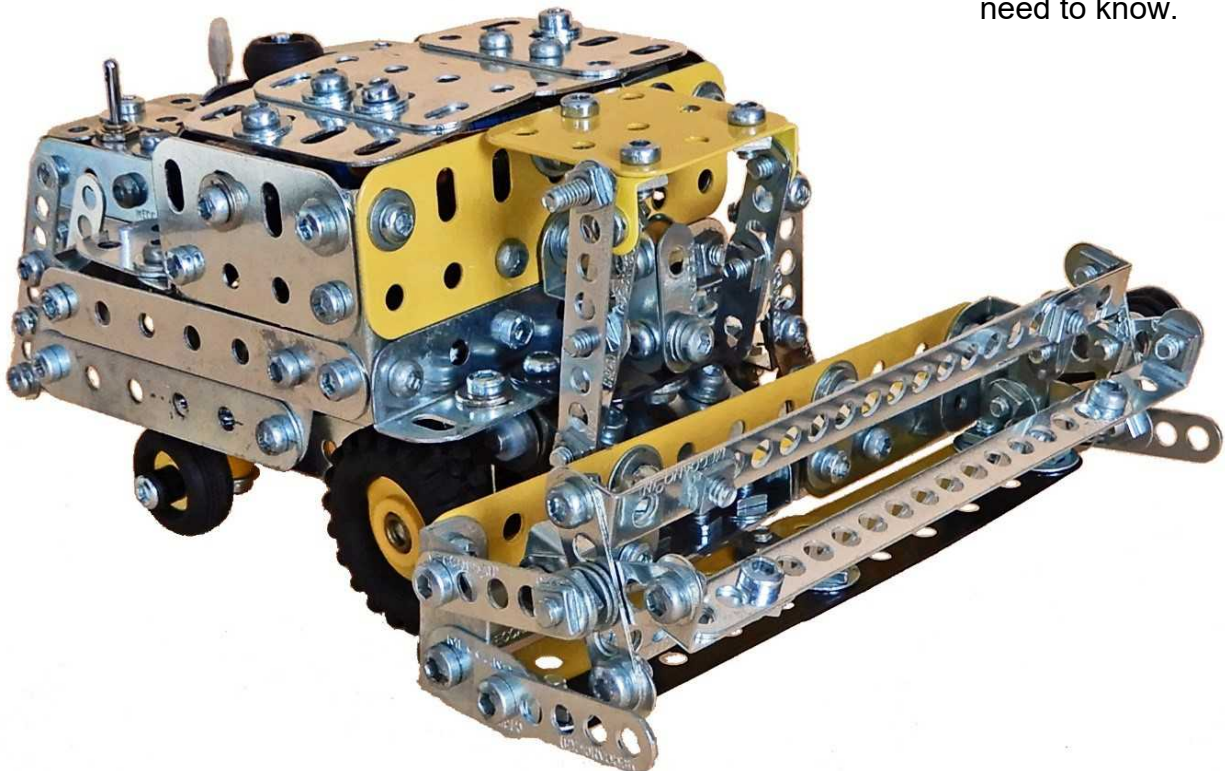

Published by The New Zealand Federation of Meccano Modellers

Volume 43, No. 1
NZ Federation of Meccano
Modellers Magazine

Editor: Richard Feltham
 174 Brooklands Road
 New Plymouth 4310
 Phone: 027 300 2548
Email: richard.feltham174@gmail.com

Proof Reader: Bruce Geange
 4 Winchester St., Palmerston North 4412
 Email: a.b.geange@slingshot.co.nz

Deadline for May issue is 30th April 2019

The NZFMM Magazine is published four times a year in February, May, August and November. The publisher is the NZ Federation of Meccano Modellers. The purpose of the magazine is to publish articles and photographs about Meccano and Meccano models, to report the meetings of New Zealand Meccano Clubs, to print letters expressing the views of Meccano modellers, to keep members informed of future events and to print advertisements of Meccano related things. The views expressed in the magazine are not necessarily those of the editor or of the Federation.

Subscriptions run from April to March & are payable annually in March. If the subscription has not been paid by the 30th of April, the 1st edition of the new subscription year [May/June] will not be released. Subscriptions may be paid by **personal cheque** [in most currencies] or by Bank Draft payable to “**NZFMM Magazine Account**”. Please mail to Peter Hancock, P.O.Box 9125, Bell Block, New Plymouth, **New Zealand**. Please enclose with your payment your: *full name, address, telephone number & email, if available.*

Subscriptions can be made by **funds transfer** from your bank account to the **NZFMM Magazine Bank Account: # 02-0136-0166165-000**. Ensure that you enter in the “**Particulars**” section your *initials or first name*: “**Code**” section, your *family name*: “**Reference**” section, ‘2019-2020 sub’.

Paypal payments to mike@sgs.net.nz Please be aware of currency conversion rates. *Note:* Please immediately email peter@augustus.co.nz confirming your Paypal payment. Include in the body of the email your first and family name and where possible, telephone number.

2019/2020 subscription rates:

Within New Zealand: Hard copy mailed: NZ\$45.00; Electronic pdf copy NZ\$14.

Overseas: Hard copy mailed: AU\$47.00; CAN\$50.00; USA\$38; GB£29; (Euro no longer accepted by NZ banks.)

Overseas: Electronic pdf: AU\$14; CAN\$14; USA\$11; GB£8; **Note:** Euro no longer accepted.

New Zealander’s paying for overseas subscribers in NZ\$: **Hard copy only mailed Overseas:** NZ\$50.

All subscription/delivery enquiries should be directed to Peter Hancock at peter@augustus.co.nz, P O Box 9125, Bell Block, New Plymouth 4351, New Zealand; or telephone +64 (0) 274488366 (NZ local 027 4488366).

NZFMM Website:

The address is <http://www.nzfmm.co.nz> or <http://nzfmm.co.nz> The joint web masters are William Irwin and Gary Higgins. They can be contacted at webmaster@nzfmm.co.nz on NZFMM website matters.

Editorial

Nothing like starting the New Year with a challenge! **Les Megget** correctly identified the single point of failure for our type of publication; lack of involvement by those for whom it is intended. It is the contributors who make or break any hobby magazine. So I start my editorship with a plea to each and every NZFMM member — please keep sending in your material. We are all keen to see what is going on up and down the country and those photos are an important archival resource.

Our hobby is about people, as much as the models, and it is a real pleasure to be able to share in such events as **David Wall’s** Lifetime Membership Award.

Coming up we have the Easter Convention in Inglewood, 19th to 21st April. It promises to be a stand-out event and I extend an invitation to all members to attend. Let’s make it one to remember. If you are thinking of joining us I suggest you organise accommodation soon, as the Naki is a popular destination. Remember we will have an alternate program for spouses and partners who might, shock horror, find a 5/32 centred universe a tad arcane.

Lastly I welcome any suggestions you might have for changes to the magazine, either in content or format. I have large shoes to fill, as so aptly described by David in his letter, and I need all the help I can get!

Best wishes,

Richard F.

Letters to the Editor

Dear Sir,

On behalf of members of the A.M.G. I wish to thank Les Megget for his sterling efforts in editing the N.Z.F.M.M. magazine for 11 years.

Despite a frequent shortage of contributions from members (mea culpa), Les never failed to provide us with a professionally presented magazine every quarter, frequently having to prepare highly detailed descriptions of his own models.

Well done Les, and to Shirley too, for her support. We wish you a long and well-earned retirement from your editorial labours. Finally our very best wishes to Richard Feltham, your successor.

David Wall
President A.M.G.

Meccano Combine Harvester

By: Bruce Geange MWT

This small model has been based on the New Holland TX32 Combine with information coming from an early 1990s brochure. The model has two motors to do the work and steering is controlled from the air cleaner. The header can be raised and lowered from the lever beside the cab (*Lower image: Cover*)

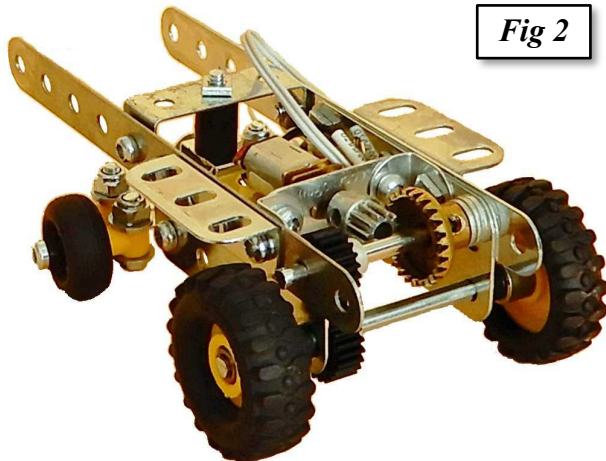

Fig 2

Start by bolting a $1\frac{1}{2}'' \times 1\frac{1}{2}''$ Flanged Plate to two $2\frac{21}{32}''$ Flat Girders by the round holes. To the slotted holes bolt a $5\frac{1}{2}''$ Strip with an Angle Bracket starting at hole three and a $1\frac{1}{2}''$ Angle Girder on the outside by the round holes. (*Fig 2; Above*).

Bolt a $1\frac{1}{2}'' \times \frac{1}{2}''$ Double Bracket in hole seven spaced with a Washer either side with a $\frac{1}{2}'' \times \frac{1}{2}''$ Narrow Double Bracket fixed to the centre hole with two Plastic Spacers and two Washers. Next bolt a Stan Baker No 1 6v, 40 RPM motor to a $1\frac{1}{2}''$ Strip with holes drilled to suit the motor mounting holes and fix to the angle brackets. Secure an eleven tooth Pinion to the output shaft. Fit a 2" Triaxle in the second top hole from the front with three Washers, $\frac{3}{4}''$ Contrate Wheel, Plastic Grip and a $\frac{1}{2}''$ Triaxle Pinion. Fit a 3" Triaxle to the lower holes with a $\frac{3}{4}''$ Triaxle Pinion and Plastic Grip. 1" Pulleys fit on the axle with the right side having a Grub Screw and spaced with a Mini Plastic Spacer. The left side has a Mini Plastic Spacer, 1" Pulley loose on the shaft and held with a Plastic Grip. A Tractor Tyre is fitted to each wheel.

For the steering axle bolt a $\frac{1}{2}'' \times \frac{1}{2}''$ Narrow Double Bracket to the centre hole on an 2" 7 hole Narrow Strip. Each end has a Steering Arm fitted using 15mm Pivot Bolts with a Washer under the bolt head and Nylock Nuts. The tie-rod is the same with the washers under the nuts. This assembly fits to the DAS on the combine with a 1" Axle Rod having two Washers at the front and a Plastic Grip

at the rear. $\frac{1}{2}''$ Plastic Loose Pulleys with Aero Tyres are used for the rear wheels and are fixed with 15mm Pivot Bolts plus a Mini Plastic Spacer on the outside.

The cab section of the model was built around a $3\frac{1}{2}''$ Angle Girder and a $3\frac{1}{2}''$ Flat Girder with the two joined by the round holes with a $1\frac{1}{2}''$ Flat

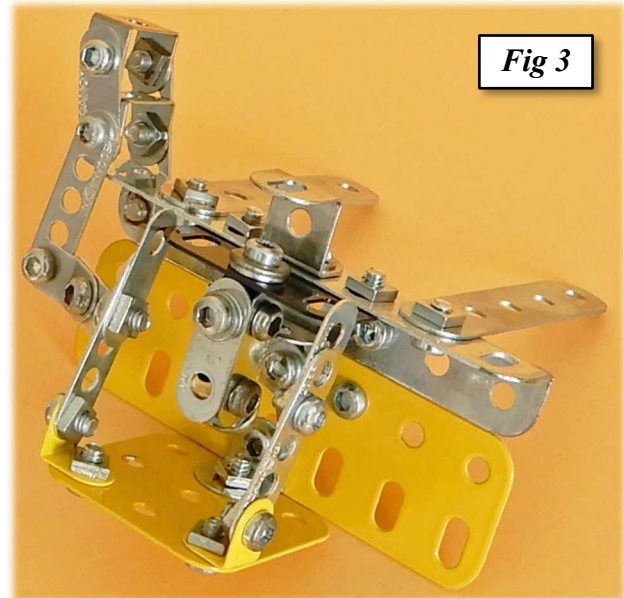

Fig 3

Girder. Bolt an Angle Bracket to the centre hole for the seat and one at the top for the roof. The cab floor is an $1\frac{1}{2}''$ Flat Girder fixed by the round holes to the slotted holes on the AG. $2\frac{1}{2}''$ Strips are bolted next to the FG facing the rear. Bolt a $\frac{1}{2}''$ Reverse Angle Bracket by the slotted hole facing to the front. The steering column has three 1" Narrow Strips fixed to a Four Hole Collar at the base and a Collar at the top with $\frac{3}{8}''$ Bolts through the centre holes. A Washer Nut and Bolt represent the steering wheel. The assembly bolts to the front

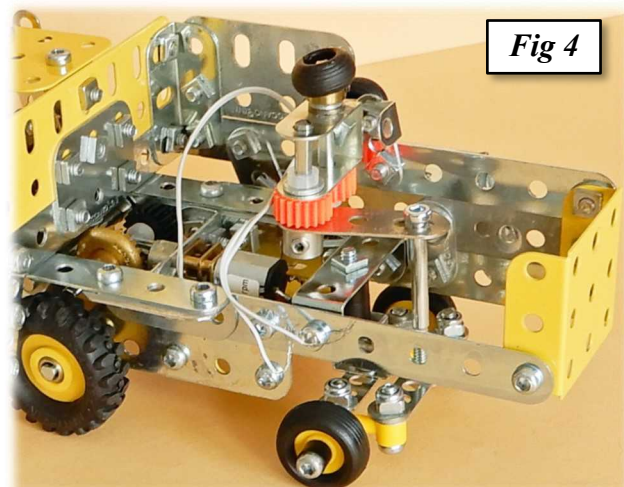
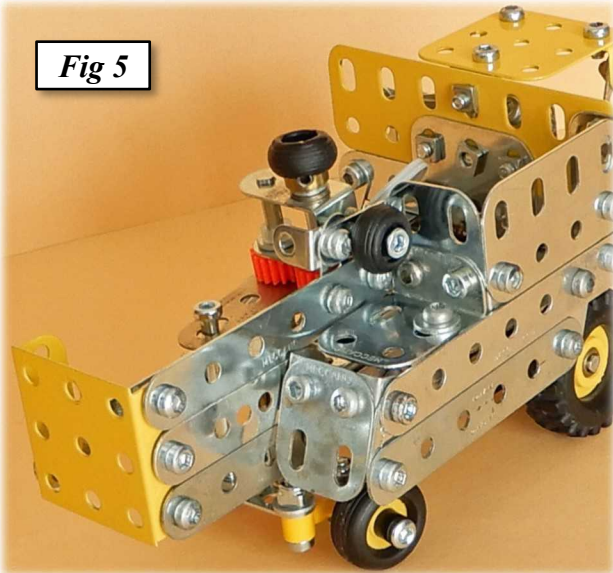

Fig 4

centre hole on the floor. The cab roof is as seen in fig 3 (*Above:*)

The strips right side cab support are joined with a $\frac{3}{8}''$ Bolt and Nut facing out. This bolt holds the

Fig 5



header up or down. The steps have a $1\frac{1}{2}$ " five hole Narrow Strip with $\frac{1}{2}$ " Narrow Double Brackets bolted to holes one and three. The other side has 1" Narrow Strip and a $1\frac{1}{2}$ " five hole Narrow Strip with an Narrow Obtuse Angle Bracket and a 1" three hole Narrow Strip at the top. The steps bolt to the angle girder. This assembly bolts to the main frame angle girders with four Nuts and Bolts.

At the rear end bolt a $1\frac{1}{2}$ "x $1\frac{1}{2}$ " Flanged Plate spaced with a thin Washer either side. On the right side at the rear of the cab (Fig 5 Above:) bolt a $1\frac{1}{2}$ " Angle Girder by the slotted holes with a $3\frac{1}{2}$ " Strip bolted to the lower round hole with a 2" Flat Girder above fixed with two Bolts and Nuts. Bolt a Fishplate to holes 2 and 7 fixed at an Angle with an Angle Bracket at hole 7 by the slotted hole. A 3" Strip bolts to the fishplates. Bolt a 1" Flat Girder to the angle bracket by the round hole with a second Angle Bracket in the next hole by the round

Fig 6

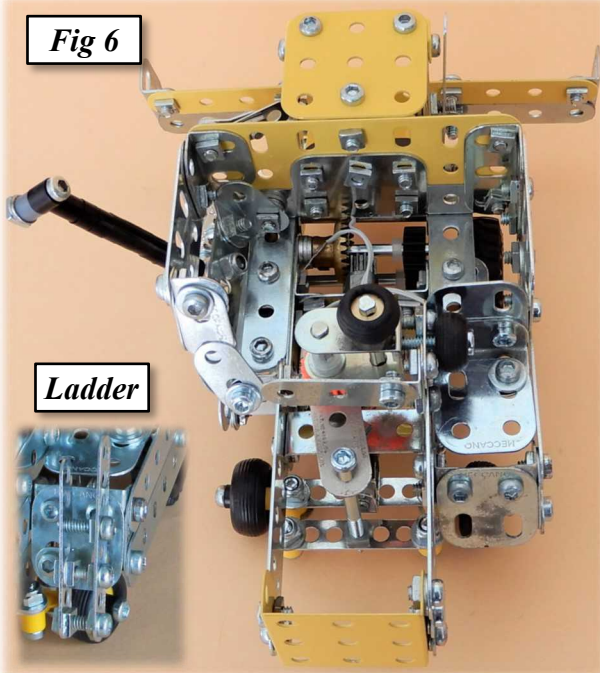

Ladder

hole. To the centre hole on the rear FP on the right side bolt a 2" Strip and a 3" Strip to the top hole both spaced with a thin Washer. Bolt the second AB to the front hole on the 2" strip with a Fishplate next to the nut with other end bolted to the lower strip. Bolt an Angle Bracket to the front hole of the 3" strip by the round hole facing out and a 1" three hole Narrow Strip in the next hole facing up.

Fig 7

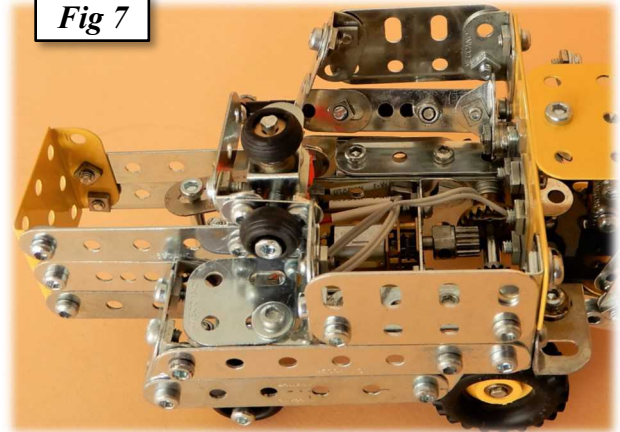
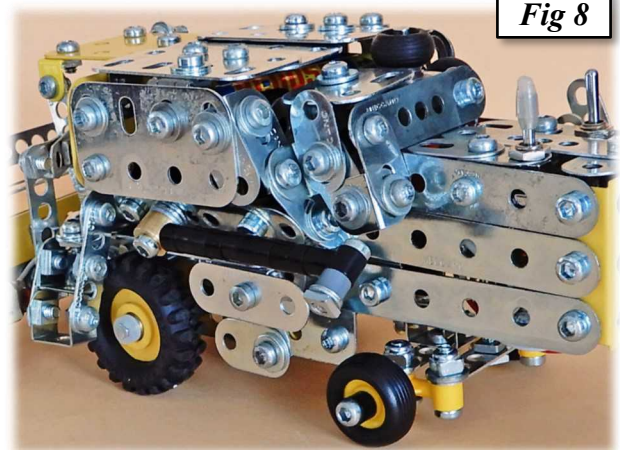

Fig 8



Bolt a 1" Angle Girder by the round holes with a Flat Girder to the front angle bracket. A second Angle Bracket is used to bolt to the 2" flat girder. Bolt another 1" Flat Girder to the slotted holes on the angle girder.

A second 1" three hole Narrow Strip bolts to the first one facing forward with a Narrow Angle Bracket at the rear and a Nut and Bolt in the end hole. A $\frac{3}{4}$ " Bolt fits through the centre hole with a Plastic Spacer and Aero Tyre and holds a 1 "x $\frac{1}{2}$ " Double Bracket for the steering (fig 6 left:).

Fit a Collar with an Aero Tyre plus a Washer to a $1\frac{1}{2}$ " Tri-Axle and place through the DB with a $\frac{1}{2}$ " Plastic Tri Hole Pinion and Plastic Grip. The end hole has a $1\frac{1}{4}$ " Tri-Axle with a Plastic Grip and Washer with another $\frac{1}{2}$ " Plastic Tri Hole Pinion and a Crank. Fit a 44mm Pivot Bolt through the

crank and secure to the steering tie rod with two Nuts. The ladder at the right rear consists of Narrow Strips, $\frac{1}{2}$ " Bolts with Nuts and one Narrow Angle Bracket.

On the left side (*figs 7 & 8 .*) bolt an Angle Bracket to the end hole on the $2\frac{1}{2}$ " strip by the slotted hole facing down. To this bolt a Fishplate and a $1\frac{1}{2}$ " Strip by the centre hole with a second Fishplate fixed below. Bolt a 1" Angle Girder to the rear of the $3\frac{1}{2}$ " FG. by the slotted hole with a 2" Flat Girder fixed to the round holes with two bolts. Bolt an Angle Bracket

Fig 9

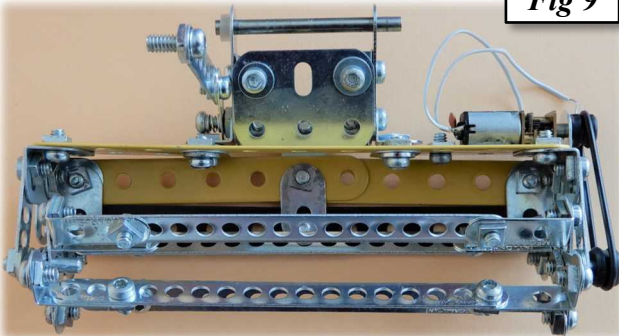

Fig 10

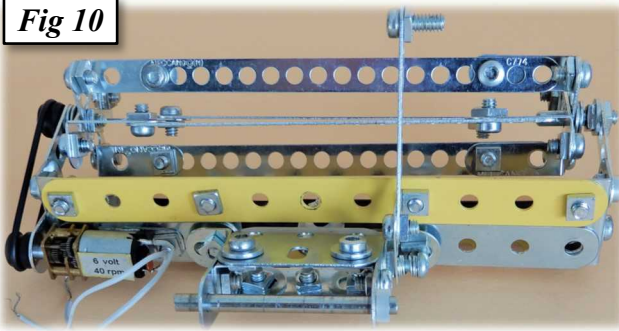
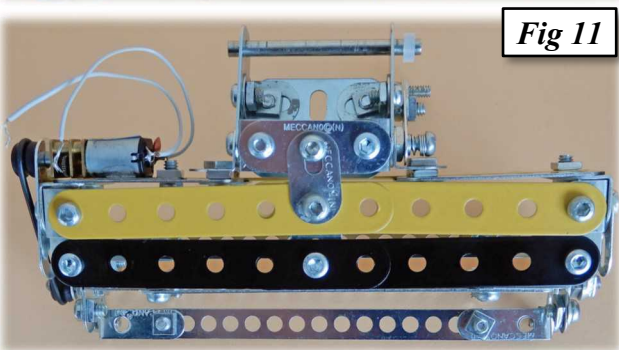

Fig 11



et with a Fishplate to the end slotted hole fixed at an angle. Bolt a Fishplate to the other hole in the angle bracket. This fishplate extends with another Fishplate and Angle Bracket facing rear bolted by the round holes, fishplate facing in with an Angle Bracket fixed by the slotted hole facing the front. Bolt a 3" Strip to the centre hole on the rear FP. spaced with a Washer and bolted to the angle bracket at the other end. The rear facing AB has a Fishplate bolted either side by the slotted holes. Bolt an Angle Bracket to the lower fishplate facing in with a Fishplate bolted to the other hole facing up. A 2" Strip Bolts between the fishplate and the narrow angle bracket. Bolt a 2"

Strip to the top hole on the FP spaced with a Washer. With a $\frac{3}{8}$ " Bolt fix a Small Trunnion in the second hole on the $3\frac{1}{2}$ "AG. spaced with four Washers with a 2" Strip secured to the single hole side. Bolt a Collar spaced with three Washers to the second hole on the 2" Strip fixed with a Nylock Nut. The discharge auger has a 2" Threaded Rod with nine Mini Plastic Spacers and a Threaded Rod End Eye. The end has a 15mm Pivot Bolt and a Mini Plastic Spacer with a Washer and Nut.

The feeder unit from the header to the combine (*figs 9, 10 & 11*) consists of two $1\frac{1}{2}$ " Strips with Angle Brackets bolted either side at the front end by the round holes The strip that becomes the right side has a 1" three hole Narrow Strip on a $\frac{3}{8}$ " Bolt with a 6.5mm Spring and Nut fixed to the strip. The narrow strip extends with a $2\frac{1}{4}$ " eight hole Narrow Strip with the Nut facing out and a $\frac{3}{8}$ " Bolt and Nut at the end. This lever raises and lowers the header. The inside AB. face down at an angle and the outside AB. face the front. Hole two has two more Angle Brackets bolted by the round holes. Bolt a $1\frac{1}{2}$ " Flat Girder to these angle brackets by the slotted holes with a $1\frac{1}{2}$ " Strip across the lower front AB with a Fishplate in the middle hole and two $3\frac{1}{2}$ " Strips lapped three holes to the fishplate with a second Fishplate on top extending forward becoming the first part of the header. Bolt Fishplates by the slotted hole, four holes from either end of a $5\frac{1}{2}$ " Strip with the lower holes having 2" Strips fixed facing either end. These bolts carry extra nuts that fix to the angle brackets that face forward on the feeder. Bolt an 1" Angle Girder by the round hole to each end of the $5\frac{1}{2}$ " strip with the top slotted holes having a $1\frac{1}{2}$ " five hole Narrow Strips fixed at an angle. Fix a 16mm Threaded Pin to the end hole on the right side narrow strip. The lower hole on the left has a $1\frac{1}{2}$ " Strip and an Angle Bracket fixed by the round hole on the inside. The right side has a Fishplate and an Angle Bracket. Both angle brackets bolt to the ends of the $3\frac{1}{2}$ " strips with Fishplates facing forward with a $5\frac{1}{2}$ " Flexible Strip bolted to the three fishplates. Extend the fishplate and $1\frac{1}{2}$ " strip with $1\frac{1}{2}$ " five hole Narrow Strips. The left side also has a 1" Narrow Strip spaced with a Mini Plastic Spacer.

The left side of the reel consists of two $1\frac{1}{2}$ " five hole Narrow Strips with a 16mm Threaded Pin fixed to the middle holes making a cross. To the ends of the strips add $1\frac{1}{2}$ " Narrow Angle Brackets. The right end is the same with a temporary bolt in the middle. The angle brackets should face each other. These are joined by four $3\frac{1}{2}$ " thirteen hole Narrow Strips. Remove the temporary bolt and fit to the header as shown with Washers as required. A Rubber Pulley fits on the threaded pin on the left side. A Stan Baker 6v 40 RPM No.1 Motor has had a strip soldered to one side with a bolt hole in and fixes to the rear left side of the header with another Rubber Pulley on the shaft. A small driving belt connects

between the pulleys. Bolt a 2" Strip to the 1" narrow strip for the belt guard spaced with two Washers. This unit fits to the front holes on the main frame with a 2" Axle Rod and Plastic Grips. You will need to remove a wheel. Extend all wires to the rear of the combine.

The switches mount on top at the rear with the one on the right driving the header and the left driving the combine forward and reverse. The switches bolt to the drilled out round hole on a Fishplate and mount on Angle Brackets and extent forward with a second Fishplate. The centre top hole at the rear has a Threaded Boss carrying a 1½" and 2" Strips. A 2½" Flat Girder bolts to the base of the grain hopper spaced with a Plastic Spacer for the batteries to sit on. Four AA batteries in a holder fit in here. When all wires are connected and the model tested the grain doors can be added. Each door was constructed from two 2" Flat Girders with a hinge at the slotted hole end in hole three from the front. More details in *Fig 12, Below*.



"Don't interfere, dear. He's got to learn by his mistakes."
(*Punch* 1948)

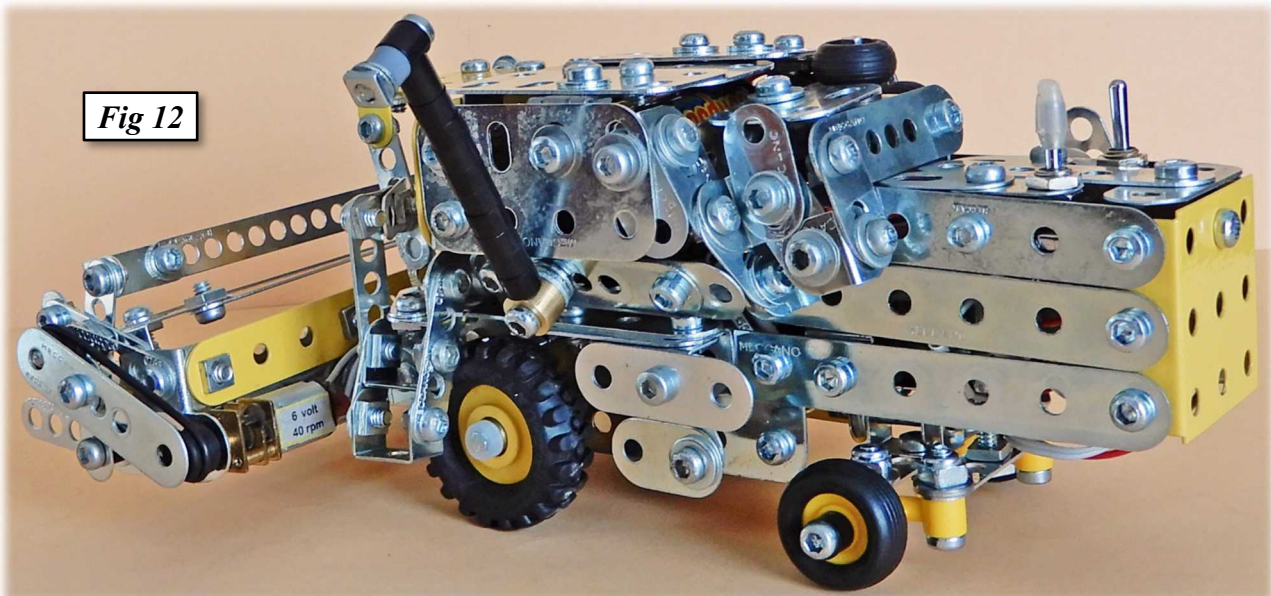

Fig 12



Above: Christmas display by Bruce Geange at Feilding's Santa Cave.

Smarten Up Your Meccano

By: Bruce Durdle (MWT)

The best way to get a grasp on what can be achieved by smartening up Meccano projects is to apply it to a real exercise. As a starting point, I want to look at a simple project that can be extended into something a lot more complex – an overhead travelling crane. In the real world, these can be found in many places. An actual crane usually involves three movements – (along the workplace; across the workplace; and up/down). I'll initially look at what is involved in one of the horizontal systems, which can be duplicated for the other.

The process of creating a smart system needs to be disciplined, to avoid ending up with an overly-complex system that does things it shouldn't and doesn't always do what it should. This brings us to the first question:

What do we want to do?

In technical terms, this is referred to as a "Requirements Specification".

A good place to start for a Meccano project is to sketch a rough diagram. This can be labelled to identify the main bits that are going to be included in the operation. It doesn't have to be complete or show all the details – just the parts involved with the "smart" activities, and how they relate to the overall layout. In a Meccano context, some crucial dimensions can be shown as well – but the main emphasis is on how things interconnect. The diagram is a sort of anchor to work with – it's a starting point to which we can add details as they emerge.

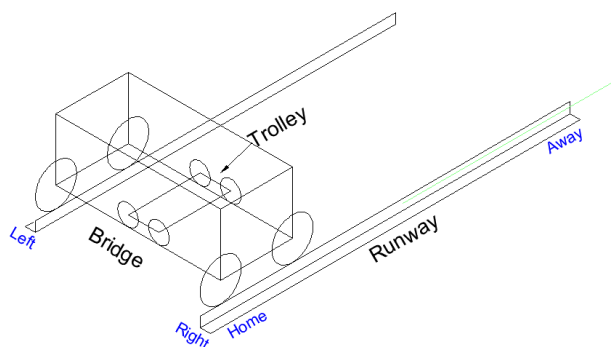

Travelling crane - basic elements

For the travelling crane, there is a fixed track (the runway) carrying the bridge assembly, which also has a track with a trolley moving on it. The trolley will also carry a winch, but at this stage let's just

focus on the requirements for the tracks and the items that move on them.

An important use for a diagram is to define the terms – just by labelling the parts, you have come up with names you can use when referring to them. For the crane, we also need to identify directions, as we will see later.

Now we can think about what we want to do. In this case, it's pretty simple - we want to be able to move the trolley between left and right ends of the bridge, and stop at any intermediate position.

The next step is very important, yet is often completely overlooked. We also need to think about what we don't want to happen. In this case, we want to make sure the trolley stops before it hits mechanical limits at left and right ends. So we need some sort of sensor at the ends of the bridge to stop the trolley moving once it reaches the ends of the permitted travel range.

We can summarise all this quite simply:

“The trolley must be able to move between left and right limits on the bridge, with positive stops at the two ends of the travel range.”

How can we make this happen ?

In the Meccano world, the easiest way to move the trolley on the bridge is to use an electric motor. The battery pack included with Part 770 has a switch that is centre off and two positions giving both polarities, meaning that this standard item can be used to give manual control of the trolley position. This is adequate to meet the movement part of the specification, but has no provision for adding limits. As long as a responsible person is in charge of the switch, that's fine, but there will always be times when we want to allow others to have a play (and distractions can occur even with the most responsible crane operator!). There's enough grunt in the standard motors when geared down to a suitable speed to cause damage to something – I managed to snap a Part 1B when something went wrong and a trolley kept driving although it had hit the end of the strip.

The fun starts when we look at possible ways of stopping the motor when the trolley hits a limit. Simple – we can just install switches at either end of the travel range and connect them in series with the motor circuit. The only problem with this is that reversing the motor drive switch will then have no effect, so the trolley cannot be driven away from the limit position. Judicious use of a finger will fix that but rather gets away from the point.

Note that the original specification doesn't cover this point. Usually, the expected normal behaviour is easy to specify in sufficient detail – the problems arise with abnormal behaviour. You need to ask:

“What might go wrong?”

And

“What should happen when it does?”

When we get to a limit, we have to stop any further attempt to drive in that direction, but need to be able to reverse the motor so it can be driven away from the limit position. Adding this requirement to the specification gives:

- A. ·The trolley must be able to move between left and right limits on the bridge.
- B. ·When the trolley reaches a limit position,
 - ~ further movement in that direction must be stopped.
 - ~ the trolley must be able to be driven away from the stop.

So now the problem is a bit better defined, we can look at possible ways of doing the job. First, we have to have something to interfere with the circuit that can be used to sense when the trolley is at the limit positions. While there are a lot of options available for this, the aim should always be to keep things simple, and some form of mechanically-operated switch is perfectly adequate for this job. But how can the requirement that the trolley can be driven in one direction but not the other when at the stop be satisfied?

Using a DC motor, the direction of rotation is set by the polarity of the applied voltage. So we can meet this requirement if we can somehow arrange things so that when a limit switch is made, the supply is effectively cut off in the polarity that would drive the trolley against the switch, but free to flow in the opposite direction. There is a device that can help with this: the standard rectifier diode conducts current if voltage is applied in one direction (“forward bias”) but doesn't conduct if the voltage is applied in the opposite direction (“reverse bias”). Two diodes connected in parallel but in opposite directions will allow either polarity to pass, and so allow the motor to move in either direction in the normal range. To prevent movement in one direction, all that is needed is to break the circuit through the appropriate diode when the limit switch is made.

Now for the deep technical detail...

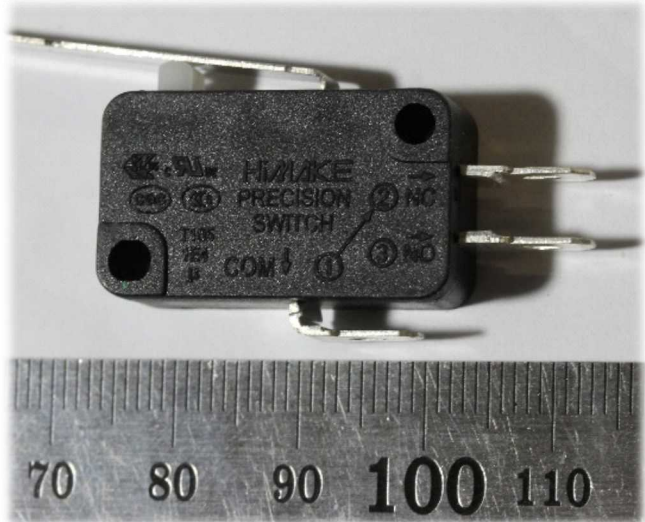

First, what sort of sensor is needed? In this case, a simple mechanical switch will do the job, but on the electrical side it has to carry current when not pressed and break the circuit when it is pressed. The description for this mode of operation is “normally closed” or NC. In practice, most switches will have three terminals with a common or pole terminal being connected to one output when inactive and the other when active – a “double throw” switch. Terminals will be labelled NC, NO, and C or COM for “normally closed”, “normally open”, and “common”. We can connect the power supply to the “C” terminal and the diode to the “NC” terminal, and the circuit will be complete when the switch is not pressed and broken when it is pressed.

The control switch has to be able to affect two circuits, as we want to change both connections between the battery and the motor. It also needs to have a neutral position when both circuits are broken. The technical description for this is DPDT (for double pole, double throw) with centre OFF.

How about the diodes? The limiting factor here is the current they are required to carry. The standard motor draws about 0.1 A when it is not loaded, but the current depends on the load and with a reasonable mechanical load applied the current draw increases significantly. A diode rating of around 2 A will probably be suitable. (*See notes below*)

The next diagram shows the wiring schematic for the control circuit .

The symbols for LL_T and RL_T are used in control schematics for normally closed switch contacts. Apart from the diodes, there is no fancy electronics in this system, but it has added a basic level of improved performance. I don't know if it meets the definition of “smart”, but it does have enough “sense” to get itself out of a fault condition.

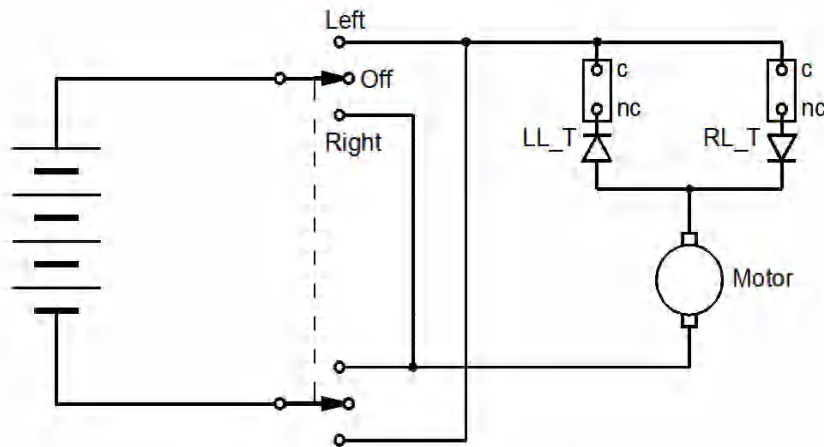

LL_T - Left limit - trolley
RL_T - Right limit - trolley

Trolley Drive Motor Schematic

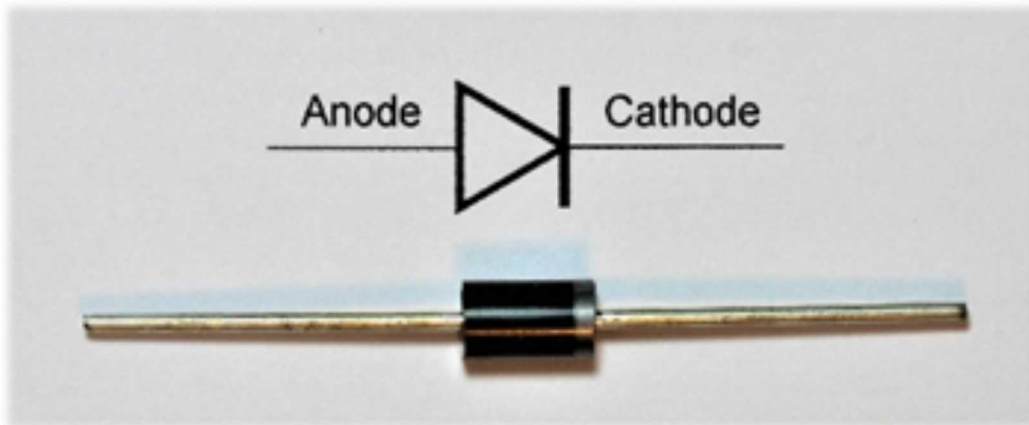

Left top:
Circuit
schematic of a
diode.

Left bottom:
Corresponding
image of the
physical
object.

Semiconductor Diodes

A diode is a two-terminal device, and while there are a number of different types varying in detailed design and characteristics most of them have similar behaviour. You will probably have come across Light Emitting Diodes (LEDs), which emit light when current flows; another common type is the Zener diode which is used as a voltage regulator.

The symbol for a diode is an arrowhead with a bar. If the arrowhead end or anode is made positive relative to the bar end, the device is forward biased. Most small diodes have a stripe at one end – this is the cathode, and corresponds to the bar on the circuit symbol.

The main characteristic of most diodes is that they conduct electricity better if the anode voltage is more positive than the cathode than they do if the voltage is reversed. Think of them as the electric equivalent of non-return valves. The polarity of the voltage when current flows is referred to as “forward bias”, while the reverse polarity is termed “reverse bias”. When forward biased, a diode will usually have a relatively small voltage drop which depends on the material it is made from – for the usual silicon diode, this voltage is around 0.65 V. An LED will emit light when it is forward biased, but not when it is reverse biased, and because it uses a different material has a slightly higher voltage drop – usually between 1.2 and 1.5 V. A Zener diode behaves similarly to an ordinary diode when forward biased, but when reverse biased will conduct if the applied voltage exceeds a specific and controlled level – so a 5 V Zener diode will still have a voltage drop of 0.65 V when forward biased, but 5 V when reverse biased.

The commonest type of diode, and the one we want for this project, is usually referred to as a rectifier. It is specifically designed to convert the mains AC supply, or voltages derived from it using a transformer, into DC as required for most electronic loads. The reverse voltage it can withstand before breaking down is much higher than LEDs or Zener diodes, and usually between 300 and 1000 V.



Auckland Meccano Guild Meeting

12th May 2012

Reporter & Photos: Gary Higgins

The November 2018 meeting of the Auckland Meccano Guild was held at the home of **Les** and **Shirley Megget** at Papakura.

12 members attended the meeting, the highlight of which was the surprise award of a lifetime membership of the Auckland Meccano Guild to our humble president **David Wall** which all agreed was well deserved.



David receives his Lifetime Membership

David of course is the founding member of the club and if it were not for his continued efforts we would not be where we are today. We also presented him with a picture of his good self immensely happy playing with junior plastic meccano, this is safe for young children to play with and there is no way he could injure himself with such a set.

David brought along his variation on the Meccano Ducati monster motorcycle. As usual with David

he looks at the various possibilities of an off the shelf model and immediately must do better. His improvements were: Front wheel – Sprung tele forks, Front wheel – twin disc brakes, Rear wheel – single disc brake, Chain drive to rear wheel, saddle and top of petrol tank filled in. Perhaps we should lend David to Spinmaster as a quality control and improvements manager!

Les was fortunate that the meeting was held at his house as he has a number of models on the go and did not have to cart them about the countryside. Having completed the excellent Aston Martin DB5, which we no doubt have all seen, **Les** is building a smaller version. He cannot rob Peter to pay Paul however because **Shirley** has forbidden him to pull the original model apart. **Les** has to source more of these silver grey, non-matching plates again for this model; he has the chassis completed at this stage.

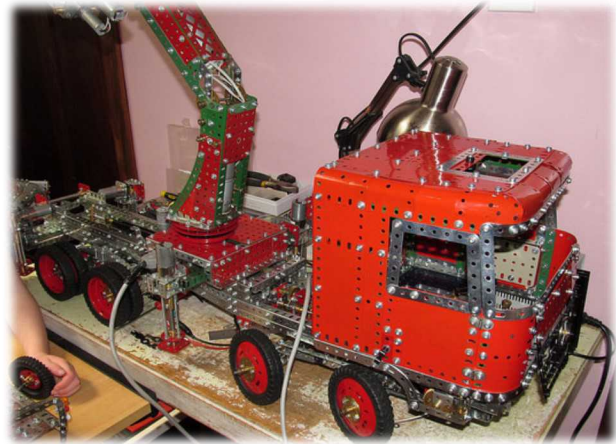

Les' Mercedes Palfinger crane

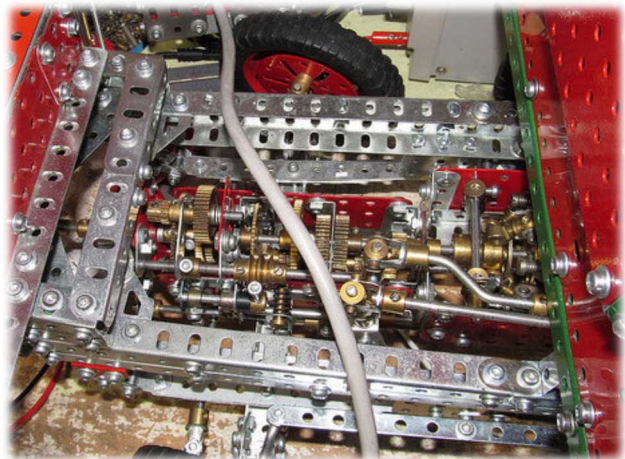

Close-up of Palfinger Crane gearbox

Les also has a large Mercedes Palfinger crane under construction which does not look to be far from completion. It has, as usual with **Les** an immense set of driving gears and gearbox, you would have to be a structural engineer to understand it ☺. One of the grandchildren was also running about with

the smaller version of the Meccano Robot, these seem to have gone quickly out of fashion. (I wonder how many they sold.)

Rick Vine had also brought along an interesting selection of models including a tank made from The Meccano Multikit Army set of 1973. He had



picked up rather cheaply a Ferrari 488 plasticano set and had built up the new Ducati Desdonmedici motorcycle with the faring's.

Rick was prepared for the hot weather and had made up a fan using the lethal early propeller blades. There was no form of protection for young fingers and I have seen how dangerous these blades are when Henry Porter mounted some on top of a tower and then had to stop it whirling about by hand, scary stuff but very effective.



Anthony Caldwell tip truck

Anthony Caldwell had made up an excellent model of a side tipping truck in red and yellow.

Gary Higgins had built up the two new tractor sets from Meccano, the original 9RT tracked tractor 17302 which makes a nice little model and has been motorized by some modellers and the newer wheeled series tractor 18302. Both of these models look good and are value for money, unlike some of the more dubious Spinmaster plasticano sets. Gary had also models of both the Ducati Monster and Ducati Desdonmedici GT which had holes missing in one of the triangular plates. I guess holes missing are easily replaced unlike some parts.

Finally he had the new Meccano F1 red racing car 18303. This is a great looking model when assembled but be warned it makes a lot of use of adhesive stickers to achieve the final look and attempting to build the upper rear engine cowling can cause extreme stress and lead to some rude words being uttered!!

Mike Stuart had brought along his enormous model of a crocodile locomotive (electric). It has been a real labour of love and we have seen it develop during the build.

Henry Porter and **Sefton Hinton** attended. Henry will be moving south to Invercargill in the New Year, a place not unlike his original home in Scotland.

Gerald Hart has been busy and back into Meccano after his recovery from an operation and brought two excellent models along.

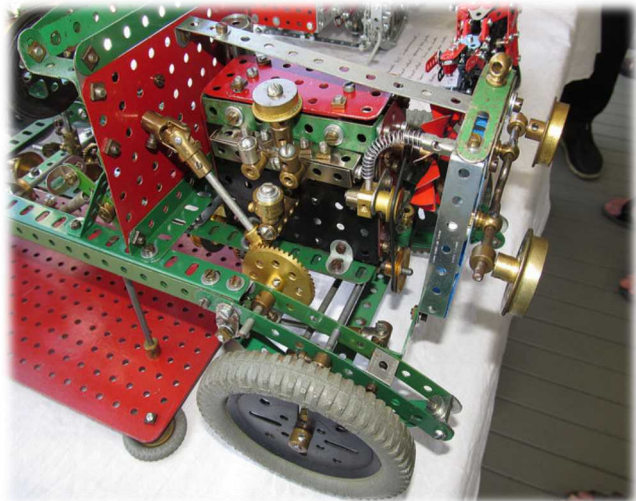

Above: Gerald Hart's model T chassis.
Left: Graeme Mills' parts roller

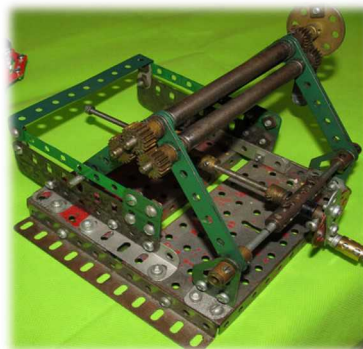

A model T truck chassis based on the Super model 1A chassis had all the parts working and Gerald had added parts to make the engine look more realistic. He also had a neatly modelled double ended Fairlie loco.

Others in attendance were **Graeme Mills** who had built up a parts roller using pre made rollers, **Neil Carey** who left his huge locomotive at home and travelled by car. Also **William Irwin** who provided us with a selection of overseas magazines.

DISPLAY WITH AUCKLAND MARKLIN TRAIN CLUB

By: Les Megget (AMG)

Photos: Les Megget & Gary Higgins

The Auckland Meccano Guild was invited to show a few models and sets at the *Auckland Out West Model Expo* by the Auckland Marklin Train Club over the weekend of 17-18 November 2018. The show was indeed held out west at the Te Atatu Community Centre, which is connected to the local Library.

My first problem was where to park near the Community Centre, which I could see but there were no apparent entry points from Te Atatu Road. After cruising around the roundabout twice, or was it 3 times (?) and a tour of the Countdown carpark next door I finally found the entrance off a cross road. Signage is nearly as bad as in the UK!

After parking I found the entrance to the show to find Gary Higgins, Elizabeth & David Wall and William Irwin setting up models and Marklin construction sets. Gary was searching for another 2 tables to make up the 6 he was promised. One he managed to borrow from the small café set up to help sustain us.

Gary had brought a selection of modern Meccano vehicle sets as well as at least 6 Marklin sets produced over many decades. It was interesting to note the differences between Meccano and Marklin parts. William showed his string pendulum clock and South Seeking Chariot, while David had several small models including his Meccanograph, (*see images*). Elizabeth was in charge of replacing the circular pieces of paper as each graph was completed. David's walking unicorn and rider valiantly tried to stay on the table all day!

David purchased some 3-rail O-gauge track, I presume for upcoming Meccano locos? I took my Merc Actros 8x4 chassis with the Palfinger crane. It behaved itself except when I tried to test its flexural strength by getting the hook caught (not seen by me) as I attempted to reel in the hook and fold up the crane. Luckily William noticed my poor crane control and averted a disaster (stripping of gear teeth).

One visitor was David Shand who had travelled up from Tauranga with a railway fan just for the day. There were a reasonable number of visitors paying to view the many train layouts and our small display, maybe 200-300, I guess. The standard of the layouts was high and there were several model train clubs represented. In fact the display reminded us of the Model-X exhibition which continued for about 30 years (over Queen's Birthday week-

end) but without the tat of Model-X in its later years.

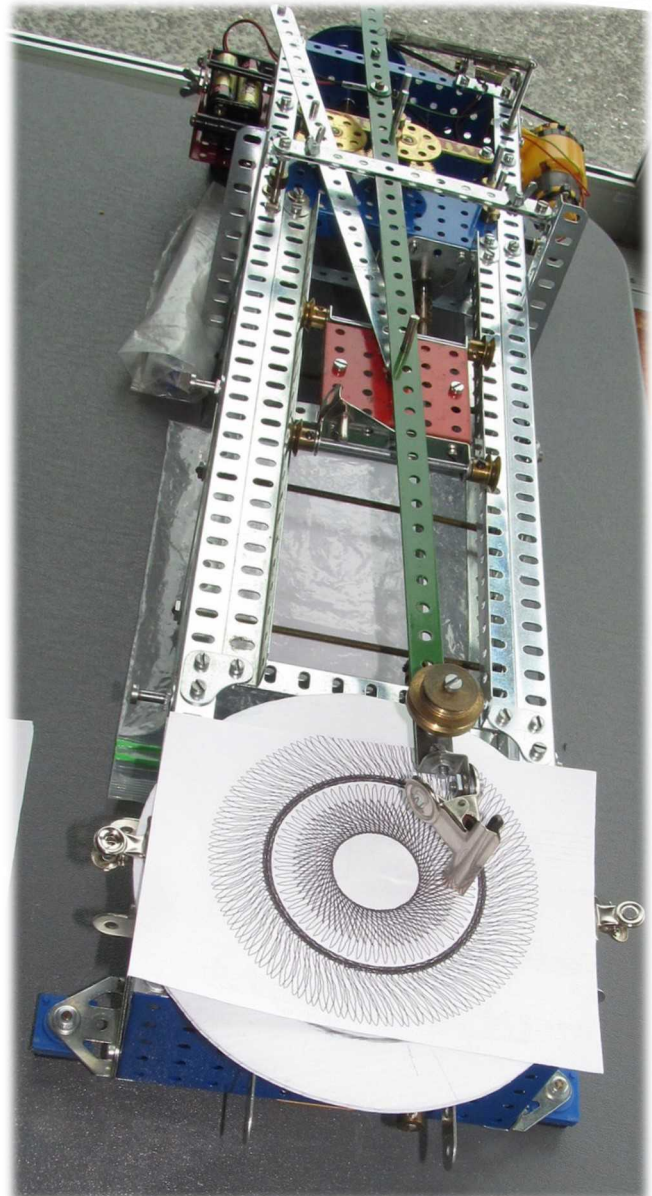

Above: Meccanograph by David (with paper changes by Elizabeth Wall.)

Below: Gary's Marklin set





Above: Hornby 0 gauge layout

Below: Gary's modern models



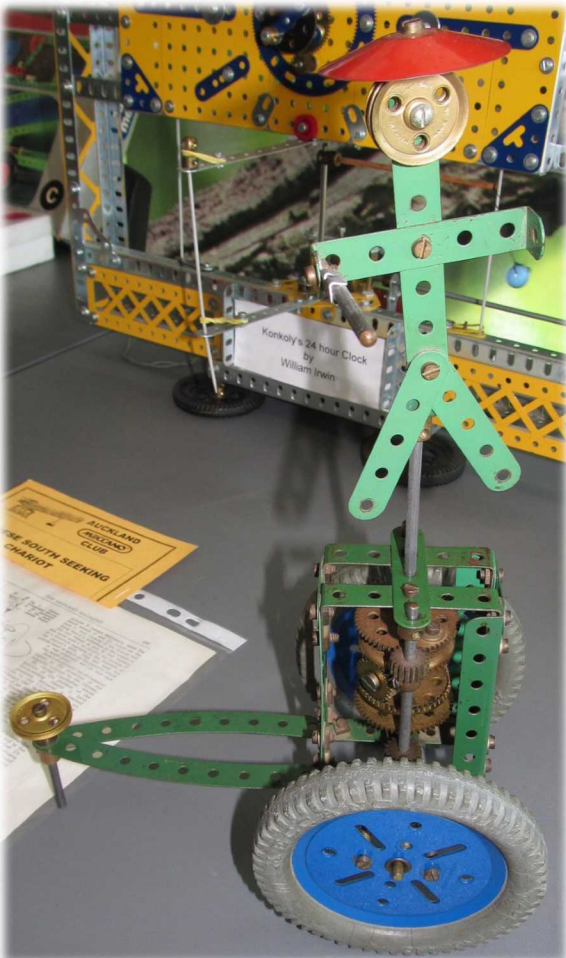

Top right: David Wall's unicorn.

Top left: South Seeking Chariot by William Irwin.
(Note: No independent confirmation available as to whether it was actually facing south... Ed.)

Below: Marklin sets by Gary Higgins.



Meccano for sale

Set No.	Name	Date	Colours	Packing	Condition	Manu-als	Price (NZ\$)
1	Meccano Set 1	1925?	Nickel	box poor	used		60.00
2A	Meccano accessory Set 2A	1925?	Nickel	box fair	used		40.00
PM	Pocket Meccano	1974	y/b/z	boxed	used	yes	20.00
2325	Erector Power Tool Set	1994	y/b/z/r	boxed	unused	yes	30.00
9515	Action Control set - Lunar	1995	y/b/z/r	boxed	unused	yes	100.00
9526	Action Control set - Construction	1995	y/b/z/r	boxed	unused	yes	150.00
4810	Mission the Universe - Defender	1997		boxed	used	yes	30.00
0020	Master Connection - racing car	1998		boxed	used	yes	40.00
0030	Master Connection - 4 wheel vehicle	1998		boxed	used	yes	50.00
0040	Master Connection - submarine	1998		wrapped box	unused	yes	60.00
0050	Master Connection - racing car	1998		boxed	used	yes	70.00
0060	Master Connection - 6 wheel vehicle	1998		plastic box	used	yes	90.00
7080	Special Edition - !00th Anniversary	1998		plastic box	unused	yes	150.00
0522	Special Edition - Big Ben	2004		wrapped box	mint	yes	60.00
8700	Design - R/C Truck, 4 wheels	2004		boxed	unused	yes	100.00
8701	Design - R/C Truck, 6 wheels	2005		boxed	unused	yes	120.00
0525	Spitfire Aeroplane	2005		boxed	used	yes	80.00
4951	Tuning Car - 2 models	2006		boxed	unused	yes	40.00
3703	Special Edition - Falcon Aeroplane	2006		boxed	unused	yes	50.00

Please contact William Irwin at willpam.irwin@gmail.com, Tel 09 4100748 or 022 3988930



Wellington Meccano Club's Brian Petersen's Prize winning Xmas train

2019 NZFMM Convention Digital Workshop programme.

Starting at **3pm** on Friday we have two speakers take us through ways to bring your Meccano models into the digital age. This is open to all registrants.

Bruce Durdle (MWT) will demonstrate how to "Hack a MAX" robot and then combine it with traditional Meccano.

In the second session **David Couch** will cover "Meccano and Computers". He will outline the practical aspects of using the Arduino microprocessor in your models. He will introduce Tim Surtell's MECControl (for those who are apprehensive about doing their own programming) and there will be plenty of opportunity to work with the software under David's supervision, so bring your laptop for a hands-on lesson. David has an Arduino starter kit to give away to someone keen to get underway in using digital control of motors and sensors.

There will be ample time for question and answer, so make the most of this opportunity to talk with computer savvy Meccanomen and take your models to the next level.

Note: The Arduino Programming Language and Development Environment will be available to load and run on your own machine to get you started in using these fantastic little devices.



Greater Waikato Meccano Club

Photos and Article : Graeme Wrightson

Ten modellers, including three from Tauranga attended and there were two apologies. The meeting was hosted by **Mike** and **Sandra Walmsley** at Paeroa.

Many members are busy building their Convention models but a number of models were brought along for display. **Dave Shand** displayed a neat Motorbike built from instructions published in a 1932 Meccano Magazine. He also had the new red Ferrari Spider Sports Car. **Mike Walmsley** showed a half-built Coles Crane that he is building from a Model-Plan and **Brian Hickson** displayed a large tractor and a half-built model of the Walking Bicycle that was featured in a recent NZ Shed magazine.

Clive Nicols presented a large collection of Army models built from the 1960's sets and **John Rickit** had built the Refuse Truck from a 1950's No. 7 manual. **Barry Babbage** brought along a nice Blue-Gold Sports Car from the 1940 No. 4 Set. **Graeme W** showed all three models built from the blue 20 Multi-Model set; all were modified and improved from the set manual.

Our young members **Hamish** and **Thomas Campbell** have been very busy and showed a range of modern Meccano models. Highlights were Hamish's menacing T-Rex, Dump Truck and John Deere Excavator and Thomas' Moon Rover, the Jet from the 15 Multi-Model set and a free-lance truck. The club presented Thomas and Hamish with a special membership Certificate each.

Following afternoon tea there was some discussion and more information about the 2019 convention was given out. This was the last meeting of the GWMC for this year but two BBQ get-togethers are planned ahead for late November and February 2019 in Tauranga. The meeting closed about 4:45 pm.

Army vehicles by Clive Nicols

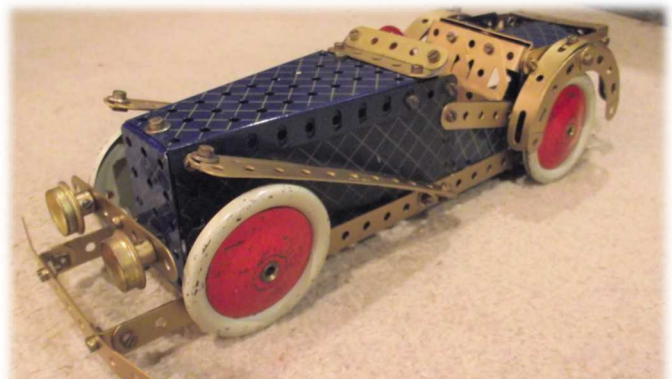
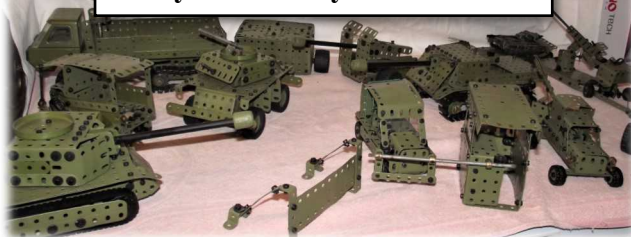

Barry Babbage's Blue/Gold Sports Car



Above: Hamish Campbell's T-Rex, Dump Truck and Deere Excavator
Below: Thomas' Multi-model Jet fighter



Dave Shand's 1932 motorbike & Ferrari

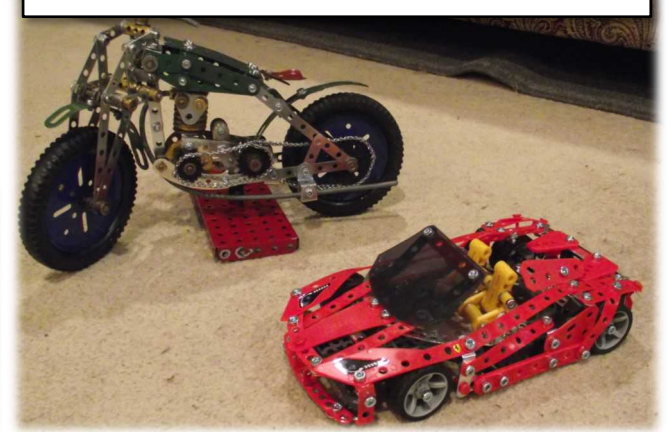

Next meeting of the GWMC - Saturday 2nd March 2019. Starts 2:00 pm. Venue to be advised.

Christchurch Meccano Club Report

December's meeting was mainly social, as expected for the time of the year. **John Stark** came down from Nelson for the meeting, so it was great for everyone to catch up with him. John brought down one of his clocks to display and demonstrate. The competition model was a Christmas Tree, with excellent entries, as shown in the photographs.

The meeting was followed by a barbeque at **Roland** and **Marlene's** the following Sunday. Great attendance, but a very warm day, so many people retreated inside. First prize winners in the model competition were **Nathan Lang** for the Juniors and **Peter Satterthwaite** for the Seniors.

At the request of members the 2019 competition will be 50/50 open models and proscribed models. Proscribed models for 2019 will be a model with max. 30 parts, something found around the house, model with three separate, controlled movements, Tank or armoured car, model incorporating six of part 214.

The Club is also grateful to Richard, for taking on the magazine editorship. It bodes well for the magazine's future.



Clockwise from top left:

- 1) **Nathan Lang**; Junior 1st Prize award.
- 2) **Nathan's** prize winning tree.
- 3) **Rob MacFarland's** tree.
- 4) **Sam "van Gogh" Lang's** tree portrait.
- 5) **Peter Satterthwaite's** Senior 1st Prize wining tree.



Thanks to Les for his long run as editor and a big welcome to Richard for taking on the role.

This month we will talk about a little known American system - **Buildo**. It appears to have been very short lived, about 1945-1947. Researching, there seems to be very little information about it. It's believed the set pictured is unused therefore a good reference set for those that may come across these parts. According to the manual that came with the set there were 4 outfits, #400, #600, #900 and #1500 (with mains electric motor) and ranged in price from \$3.95 - \$14.95

It is a 1/2" spacing system with aluminium parts and #6 UNC threads of 32 TPI. The axles are 9/64" or 3.6mm slightly smaller than Meccano. There is no parts list in the manual. The Buildo Companies HQ was in Minneapolis, Minnesota and run by a man named Weston Farmer.

So there you have it, short and sweet and will let the photos tell the story. Hoping to see you all at the Convention over Easter – **Daryl Anderson**

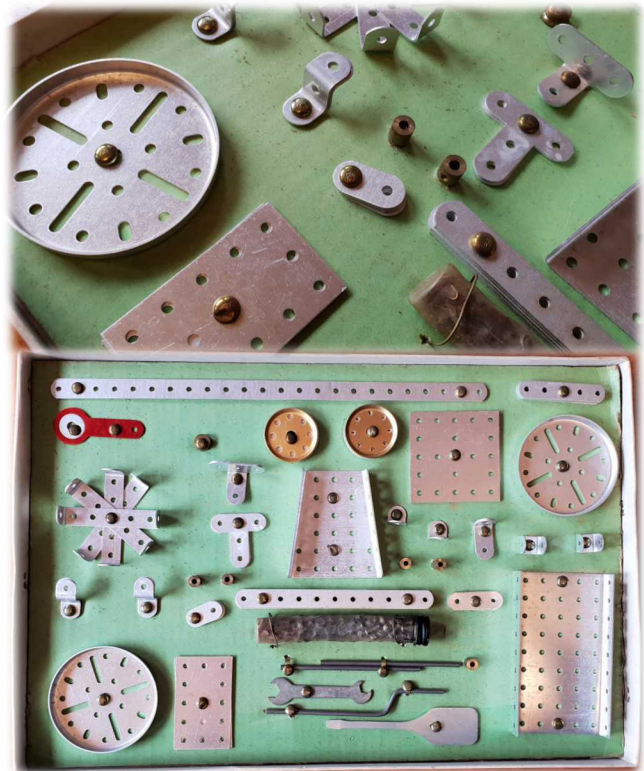

More Christmas Trees from the Christchurch Meccano Club December Meeting

Far left: Hilary Sattersthaite

Left: John Hamlyn

Right: Alex Lang's entry.



Gazza's EBay Column Garry Higgins

Well here we are in a new year and a new lot of goodies for selection. I have finally found out how to access the lot numbers thanks to one of our readers and have found they are on the main page of the lots at the very bottom in very tiny text. They will be included from now on.

Starting with lot **163428716328** a crazy inventors clock time machine consisting of 527 parts. These came out about 2004-5 and were very popular but getting harder to obtain now; selling for \$110 NZ with shipping of \$61.99 (all dollar values will be in \$NZ).



Lot 332999947728 an E20B 20 volt electric motor in royal blue, clean and running according to the seller but has been repainted. \$36.59 shipping \$37.78.

Lot 113528731918 A meccano super tool set complete in box , it does show some signs of use, missing the cellophane covering. 1970's vintage \$44.00 shipping \$61.47

Lot 113528743002 Meccano hand generator in original box with instructions, It does not look as if it has been used 1970's \$22.20

Lot 143081741442 some early meccano nickel parts including 3 of the triangular plate part (76)

the earlier patterns are hard to come by and one face plate part (109) \$3.73 shipping \$7.51

Lot 233079897485 Boxed meccano advanced design 3700 makes up two models and appears unused \$22.52 shipping \$42.56

Lot 142482822156 Meccano multikit series 2 with a polystyrene tray, still sealed from the 1970's \$281.49

Lot 401681037715 Meccano shuttle for loom, you really need one of these if you feel a loom looming, yours for only \$33.16 shipping \$36.07 no markings on these so will be a replica hence the low price.



Lot 254027275989 Vintage BRAL aero set, used and Italian made, you don't see a lot of these about \$169.36 shipping \$42.38

Lot 392125897824 Meccano pirate ship, go on you know you have always wanted to be a pirate 630 pieces \$58.90 Shipping \$43.56

Lot 132912676019 Meccano space 2501 selected spare parts , this set was out in 1979 and was one of the last series produced by Binns road, \$14.99 shipping \$40.22

Lot 342564355242 Ancient trains, wagons, Jep Meccano and Hornby, there may be some rare selections in this lot, especially the early French loco's \$82.92 shipping \$50.86

Lot 264121769669 Meccano multikit crane building set from the late 70's-80's looks like more than one set with this lot \$93.81 shipping \$90.08

Lot 153265908924 Hornby 0 Gauge Locomotive LMS2270 Clockwork loco with key in working condition \$84.41 shipping \$20.84.

Lot 233054536846 French meccano 1A accessory outfit in dark red / green listed as not complete / checked for parts \$70.00 shipping #30.00.



Lot 352426725757 BRAL construction set (Italian) similar to Meccano \$50.84 shipping \$33.91.

Lot 273646788302 No 1 Aeroplane constructor set from 1936, boxed and with instruction manual \$515.45 shipping \$25.14.

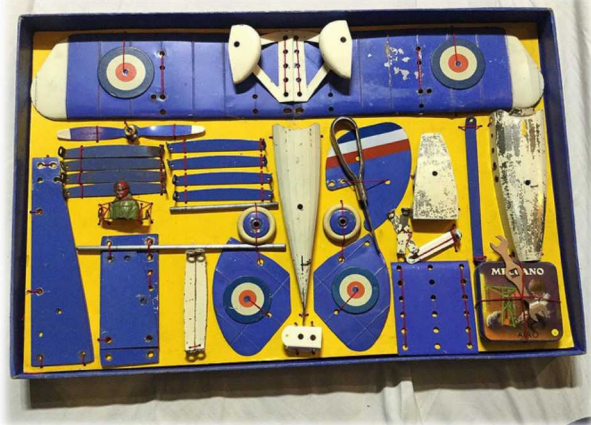

Lot 303020643531 Motor car constructor set no2 from the 1920's in red and blue, these are now highly sought after which is reflected by the price \$1,034.77 shipping \$47.03.

Lot 162964252564 Meccano 2 seater sports car no 1 car constructor with box in original condition \$1,296.02 shipping \$29.46.

Lot 273619953756 Original letters from Meccano Ltd. Binns Road from 1964 and 1970 historical value only \$37.53 shipping \$27.21.

Lot 153313707882 Crazy inventors car set 5650 in unused condition, another one of these very collectible and quirky sets \$92.87 shipping \$30.96.

Lot 322970745676 Meccano set in red green from 1945-58 box restored, restrung onto cards and parts tins have repro labels ONLY \$4,278.61 he is trying hard to sell this lot!

Lot 332856085164 A no3 blue gold set, restrung with instructions in the box \$253.24 shipping \$67.74

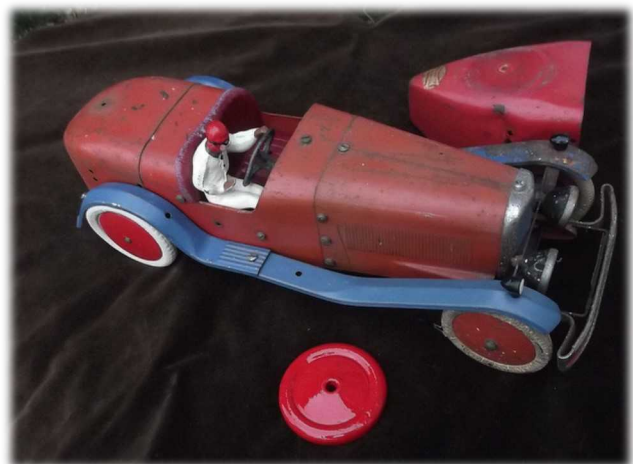

This lot (!) should keep you interested for a while, all the best for the new year and good luck EBay-ing.



Meeting Report

Date:
9th Nov
2018, 7:30pm

Reporter: Max George

The Wellington Meccano Club

Minutes: Secretary – Max George

Meeting Date: 9th November 2018 at 7:30. Held at Campbell Morrison’s place, Silverstream.

Present: Campbell Morrison, Don Flowers’ Keith McCallum, Lou Nichols, Max George, Reg Barlow, Robert Vale, Stan Baker, Stephen and Kerry Westmoreland, Trevor Green

Apologies: Brian Petersen, Ross Quayle.

Meeting – General Business: No General Business.

Models displayed: There was no model theme for the meeting.

Lou Nichols – ‘The Commemoration of WWI’ was the theme for his model.

This is a Sopwith Camel aeroplane. Note the two men servicing the aeroplane. Lou also had a display of four road wheels of different colour scheme.

Robert Vale - had made a motorcycle and sidecar #4.25 from the 1950’s manual



Max George – Again, brought along models built by members of the Tawa U3A Meccano modelling group who have been coming to his place twice a month for the past year building various Meccano models. Some from Max’s collection and others from sets that they have bought themselves. They are that keen, they want to continue with the sessions in 2019.

Set #6353 Turbo Racing Car that you can pull back and let go.

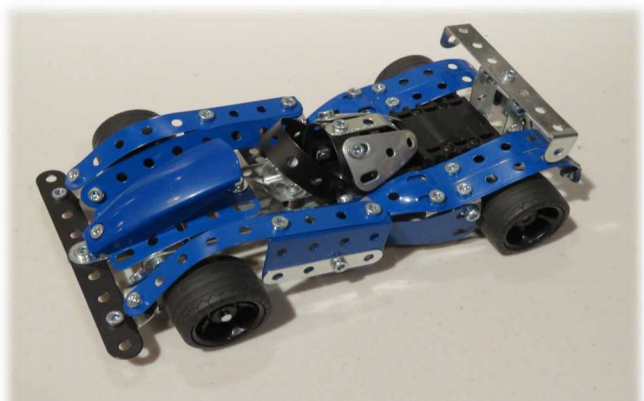

Set #6353 Turbo pull-back racer

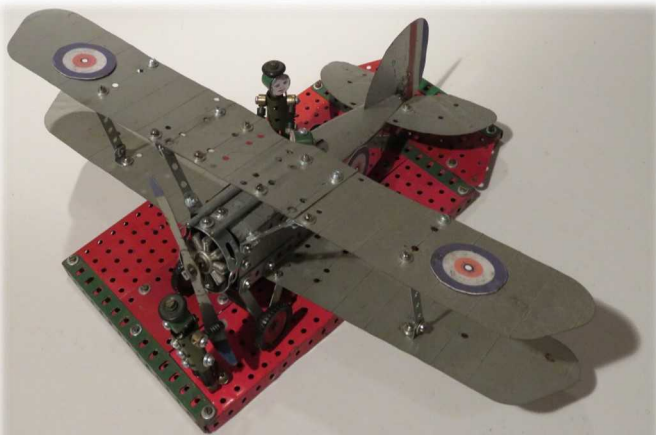

Lou Nichol’s Sopwith Camel

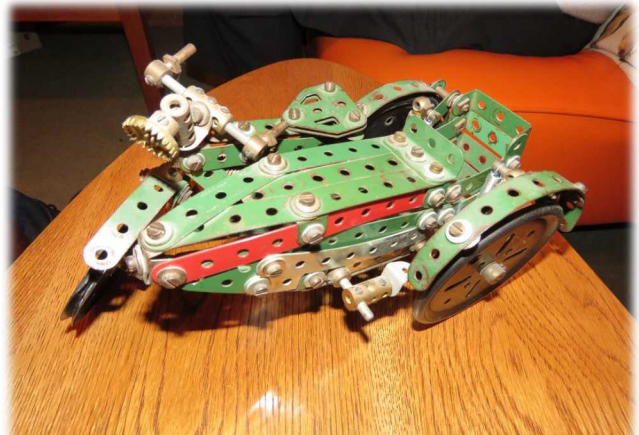

Motorcycle & sidecar by Rob Vale



Set #8541 crane with 2 motors

Crane built from Multi models set #8541 which makes use of Infra-Red Control. This crane uses 2 motors one to control driving along and the other to extend and retract the boom. A small remote controller is used for the motors. The manual contains instructions for 12 different models



Tellurium by Campbell Morrison



Robert Vale - motorbike & sidecar



Trevor Green's #6515 digger

Trevor Green - Digger built from Multi Models set #6515. Makes good use of Bowden Cables to control the movement of the boom.

Campbell Morrison – Had built a Super Model series Motorbike.

Although not Meccano Campbell displayed an Orrery, he has built up over a period of time from a magazine 'Build an Earth, Moon and Sun Orbiter' that had parts in every edition. It looked quite spectacular and worked well.

He had on display two beautifully restored sets he bought recently. These were sets that Don Wilson patiently refurbished and put together. A 1935 Set F and a 1937 Set 8.



Campbell's restored 1935 F set

Don Flowers – Brought along sets he had recently purchased. Lamborghini Huracan set (which was spoilt by having too much plastic in it) and the new Spinmaster Motorcycle.

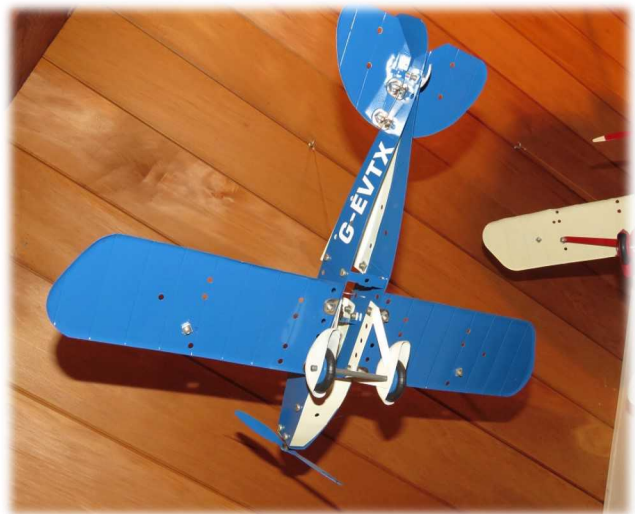

Above: Box lid of the restored 1935 Set F

The meeting closed at 10:00 pm.

To make sure we weren't looking down all the time Campbell had Meccano Aeroplanes hanging from the ceiling.

NEXT MEETING: This will be held on **Friday 1st February** hosted by Lou Nichols at the Leisure Centre of the Summerset Village, 65 Guildford Drive, Paraparaumu.

The Wellington Meccano Club Christmas Lunch

Secretary – Max George

Meeting Date: 16th December November 2018 at 11:30. Held at Fisherman's Table, Paekakariki.

Present: Brian Petersen, Campbell Morrison, Lou Nichols, Max and Gillian George, Reg Barlow, Stephen and Kerry Westmoreland.

A very enjoyable lunch was had by all with several Christmas themed models which were judged by the friendly waitress. She chose **Brian Petersen's** Christmas Train. Well done Brian. (See back cover.)

Christmas Models displayed.

Brian Petersen - Has unfortunately has been unable to attend recent meetings but brought along a Christmas Train as his Christmas themed model.

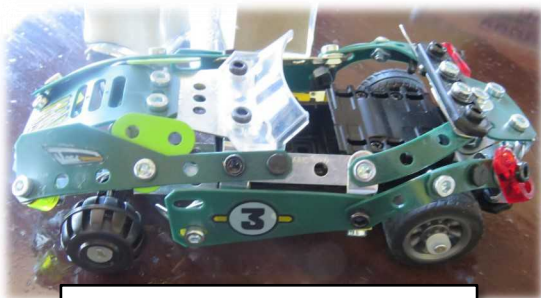

Brian's three racing cars

Stephen Westmoreland – Had a very small but effective Christmas tree. We all thought it was cute. (see page 27.)

Max George – Designed a Father Christmas which everyone said it looked more like a snowman.

Lou Nichols – Brought in an excellent Christmas tree which outdid Stephen's. All of us thought that it would be the best model.



Lou Nichol's Spectacular Tree

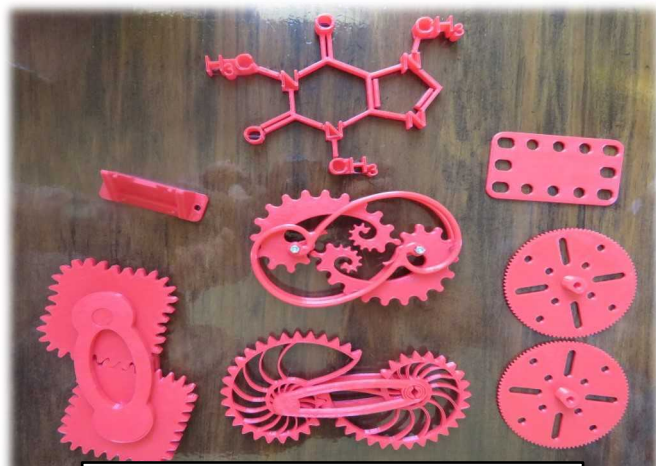

Campbell's 3D printed gears

Campbell Morrison – Has been busy trying out 3D printing and brought along some of the pieces he has made. He is looking forward to the day he can make Replica Meccano parts to replace broken or lost

MWT MEETING REPORT for 13th OCTOBER 2018



MWT Meccano Model Tour 13 October 2018

Report: Robin Rye,
Photos: Bruce Geange

Lindsay Bond Memorial Trophy: Was on display. A Meccano model of a windmill. The current holder is Richard Feltham.

Tom Pittams: A current Micronoid robot set.

Bruce Geange: A Meccano Bren Gun Carrier with operating suspension, radio controlled. A motorised combine harvester having two small motors for drive and header reel,...a New Holland TX 32 Bruce said. (See cover).

Hugh Ramage: Displayed a recirculating ball roller. Fun to build and fun to watch. Also he had one of the current Ferrari one model sets built up.

Robin Rye: Bought along another of his upcoming convention aircraft models....1958 set 8 model 13. Altered somewhat to facilitate easy dismantling for transport.

Brian Whitehead: Current John Deere crawler set.

Peter Hancock: Meccano advertising paper x much! A last effort from Binns Road in the form of a Texas Wheelie set. Peter has Meccano from Elephanta for sale at discount.

Bruce Durdle: Is very keen to utilize Meccano robot equipment and explore the use of the components elsewhere. He demonstrated a current MAX set being controlled with a tablet.

Richard Feltham: Developments of his ball lifter to operate a binary computer featured along with some mid 1960's Meccano Magazines and a small car made by his 5 year old

granddaughter.

Daryl Anderson: Dinky Builder set 0 from 1937. Convention entry forms.

Viv Alexander: The master of Meccano set box repair and manufacture did not disappoint with a 1934 G set with a 3 layered box. Other sets on display...1D Connecting Outfit, 3F Connecting Outfit, a 1934 set E for Germany and a KBN Train Set in box.

Paul Vodanovich: Again brought along his exploding ship and this time also with the submarine to launch the torpedo. He demonstrated setting the ship for the explosion and loading the torpedo and firing it. Paul's grandson loves to see the ship explode!

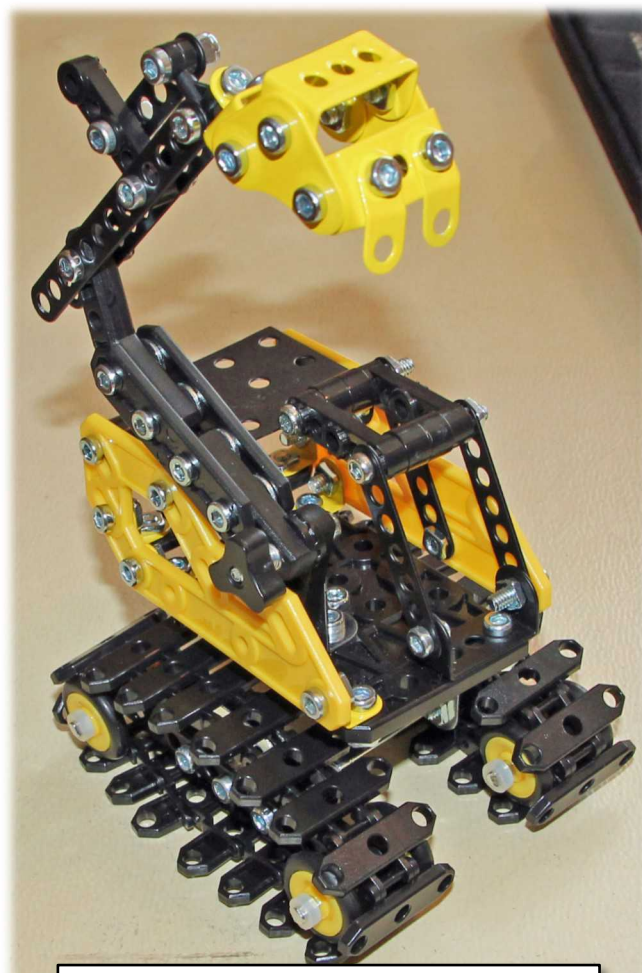

Brian Whitehead Crawler digger set.

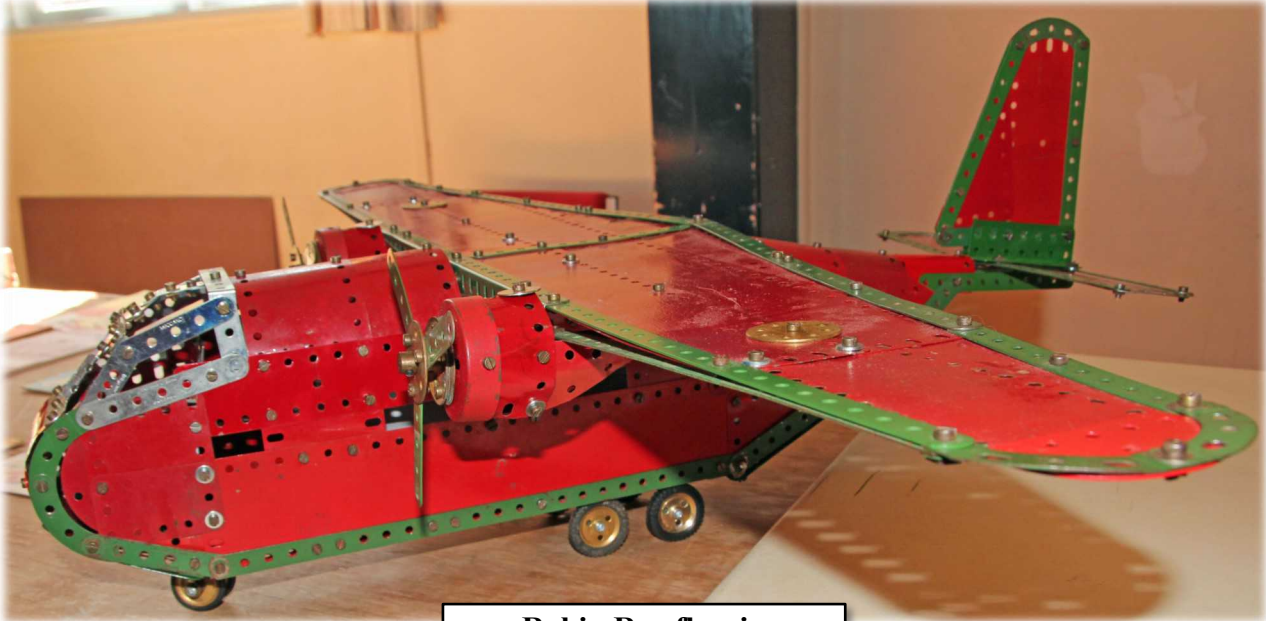

Robin Rye flew in



Viv Alexander showed a miscellany of sets



Peter Hancock's Texas Wheeler



Alien invasion

New Zealand Club Diary 2019

Auckland Meccano Guild

President: David Wall, Tel. (09) 426 1965
 Secretary: Gary Higgins, Tel. (09) 832 4292
 Meetings at 2pm on second Saturday every third month. The next meeting will be at Les & Shirley Megget's 231 Opaheke Road, Papakura on **Saturday 11 May from 2pm.**

MWT Meccano Club

Chairman: Chris Morton, Tel. (06) 323 8001
 Secretary: Robin Rye, Tel. (06) 764 8670
 Meetings at 2pm. Next meeting: **Saturday 8th February** at St. Luke's Church Hall, Corner Cornfoot and Manuka Streets, Castlecliff, Wanganui.

Wellington Meccano Club

President: Stan Baker, Tel. (04) 566 7150
 Secretary: Max George, Tel. (04) 232 4200
 Contact: Lou Nichols, Tel. (04) 297 1515
 Meeting at 7:30pm on first Friday every second month. Next meeting: **Friday 1st February** hosted by Lou Nichols at the Leisure Centre of the Summerset Village, 65 Guildford Drive, Paraparaumu.

Christchurch Meccano Club

President: Neil Pluck, Tel. (03) 389 8134
 Secretary: Roland Jaspers, Tel. (03) 351 4389
 Meetings at 7:30pm on **first Friday every month** (except January) at Papanui RSA Club, 55 Bellevue Ave or No. 1 Harewood Road, Christchurch.

Greater Waikato Meccano Club.

Contact: Graeme Wrightson
 Meetings: Saturday **2nd March** 2019. Starts 2:00 pm.

Additional Meccano Contacts

Hamilton: Don McClelland, Tel. (07) 843 4198
 Tauranga: Barry McKey, Tel. (07) 576-1623
 Hawera: Daryl Anderson, Tel. (06) 278 7666
 Napier: Trevor Adam, Tel. (06) 843 4837
 Palmerston North: Bruce Geange, Tel. (06) 357 0566
 Nelson: John Stark, Tel. (03) 545 1025

Articles, etc. for the May 2019 issue of NZFMM Magazine should be sent to Richard Feltham before the 30th April 2019. at: richard.feltham174@gmail.com

Back Numbers: NZFMM Magazines from April 2001 are available. Please contact Bruce Geange.

Buy, Sell, Auction & Exchange

*Advertisements in this section are free.
 First insertion will be printed in full.
 Subsequent identical insertions (max. 1) may be abbreviated to fit space available.*

Replica Meccano and Compatible Parts

- Fast Delivery – By far the most extensive range of new parts in the region. Over 4000 different parts ex stock.
- NZ & Australia Distributor for **Ashok Banerjee Parts**
- Very competitive prices and no minimum purchases.
- Payment to Australia or NZ bank account in or via PayPal.
- Will dispatch by courier or mail to anywhere in the world.
- Increasingly diversifying into Meccano associated items including:-
- Range of powerful small super efficient motors.
- Digital tachometers.
- 6 channel radio control systems with servos and speed controllers to suit the motor range.
- Parts fitted with miniature roller bearings.
- Bowden Cables. Ashtray tyres.
- Variable Power supplies.
- Wireless remote switches (on off and forward reverse).
- Rechargeable Batteries and holders for 5x AA batteries (6 volt).

If you need a new Meccano related item, chances are that others will too, so ask.

Money back guarantee if not satisfied.

Price list in PDF, Excel or by printed copy (30 pages) .

Contact Stan Baker nzmeccanoman@gmail.com
 Phone +64 4 566 7150 Evenings or +64 21 421 750 mobile

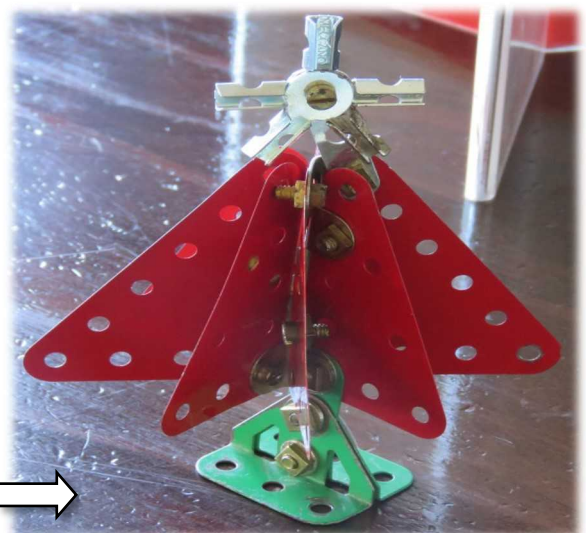

Stephen Westmoreland trades ingenuity for size



Santa, by Max George

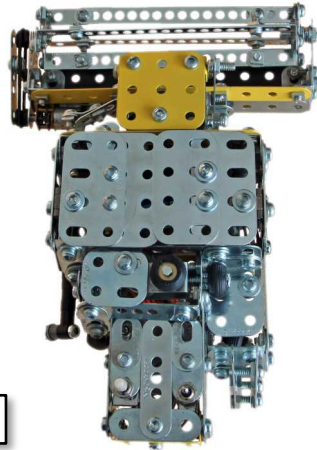

John Rickit 1950s Refuse Truck

NZFMM Biennial Convention
Easter 19th to 21st April, 2019
Inglewood Town Hall
34 Cutfield Street

Thursday: No formal activities arranged.

Friday: Exhibitor registration and model setup from **9.00am**. Please remember that any electrical devices such as multiplug boards must have been checked by a registered electrician and tagged as such. Free morning and afternoon teas will be provided at the hall, as will lunch on each day.

The official model tour will begin at **1pm**. Each attendee will be given 5 minutes to extol the virtues of their display. Audio visual gear will be available.

Our digital workshop commences at **3pm**, with Bruce Durdle demonstrating how to “Hack MAX”. David Couch follows with “Meccano and Computers” - a practical insight into microprocessors like the Arduino. (*See page 15 for details*)

There will be a free light evening meal available at the venue from 5:30ish onwards.

Saturday: Exhibitor admission is from **8:30** onwards. Public admission is from **10am** until **4pm**. Lunch will be provided for registrants.

The NZFMM AGM is scheduled to start at 5pm, and it will include our customary group photo.

The Convention Dinner and Prizegiving is from **6:30pm** at the Inglewood Club. This is within easy walking distance.

Sunday: As for Saturday, with exhibitor admission from **8:30am** onwards. Public admission begins at **10am** until the Convention closes at **4pm**. Again lunch will be provided. Clean up from 4:30 onwards.

Alternative program for spouses and partners is being arranged, although the exact nature of this will depend on numbers. Options include a tour of the house and gardens at Tupare, also various garden and park walks. Internationally recognised venues like Pukeiti are close by, as are any number of craft outlets. If wet indoor tours at Puki Ariki and Len Lye Centre will be available.

REGISTER NOW
EASTER NZFMM NATIONAL COVENTION 2019

Registration Form is on our website
www.nzfmm.co.nz

EASTER CONVENTION 19TH TO 21ST APRIL 2019